

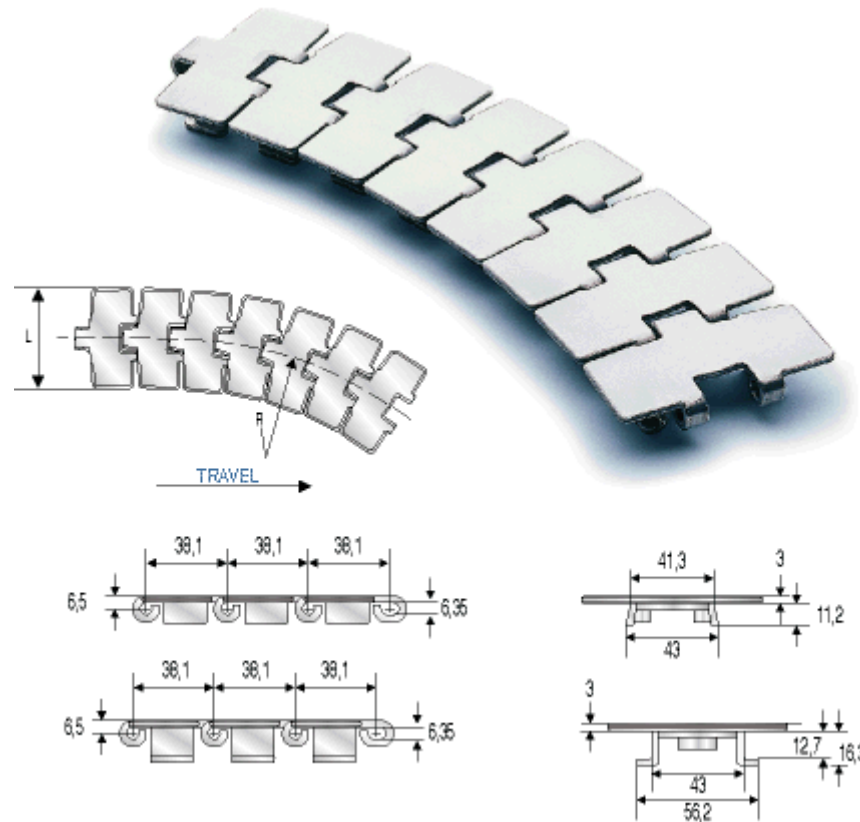

---

- Flex RXMC - Flex RXMS - Flex RXM - Flex RXM 316 - Flex RXMA -  
- Flex FMS2 - Flex FM2 - New Flex Mag - New Flex Mag-D -  
- Flex RXMS-G /New Flex-G Mag -

---



## Flex RXMC

Inox

- Ferritic, AISI 430 stainless steel slats, work hardened, with shiny surface having low roughness.

- Chrome-nickel, austenitic stainless steel pins and guide shoes (18% Chrome - 8% Nickel), work hardened for high resistance.

Model	L=Slat width		Code	Chain ref.	R=Minimum sideflexing radius	Weight per metre
	mm	"				
Flex RXMC Tab	82,6	3 1/4	8.23.041	SS 881 T K325	457	3,10

## Flex RXMS

### Hard Inox

- Special, chrome-nickel, stainless steel slats, work hardened for high resistance, with shiny surface having a roughness of Ra < 0.3 microns.
- Chrome-nickel, austenitic stainless steel pins and guide shoes (18% Chrome - 8% Nickel), work hardened for high resistance.

Model	L=Slat width		Code	Chain ref.	R=Minimum sideflexing radius	Weight per metre
	mm	"				
Flex RXMS 8°	82,6	3 1/4	S.8.23.040	SSH 881 K325	457	2,90
Flex RXMS 8°	114,3	4 1/2	S.8.23.080	SSH 881 K450	610	3,60
Flex RXMS 8°	190,5	7 1/2	S.8.23.110	SSH 881 K750	610	5,30
Flex RXMS Tab	82,6	3 1/4	S.8.23.041	SSH 881 T K325	457	3,10
Flex RXMS Tab	114,3	4 1/2	S.8.23.081	SSH 881 T K450	610	3,80
Flex RXMS Tab	190,5	7 1/2	S.8.23.111	SSH 881 T K750	610	5,50

---

## Flex RXM

### Inox 18/8

- Chrome-nickel, austenitic AISI 304 stainless steel slats (18% Chrome - 8% Nickel), work hardened for high resistance - shiny with a roughness of Ra < 0.5 microns.
- Chrome-nickel, austenitic stainless steel pins and guide shoes (18% Chrome - 8% Nickel), work hardened for high resistance.

Model	L=Slat width		Code	Chain ref.	R=Minimum sideflexing radius	Weight per metre
	mm	"			mm	Kg/m
Flex RXM 8°	82,6	3 1/4	8.13.040	SSA 881 K325	457	2,90
Flex RXM 8°	114,3	4 1/2	8.13.080	SSA 881 K450	610	3,60
Flex RXM 8°	190,5	7 1/2	8.13.110	SSA 881 K750	610	5,30
Flex RXM Tab	82,6	3 1/4	8.13.041	SSA 881 T K325	457	3,10
Flex RXM Tab	114,3	4 1/2	8.13.081	SSA 881 T K450	610	3,80
Flex RXM Tab	190,5	7 1/2	8.13.111	SSA 881 T K750	610	5,50

---

## Flex RXM 316

### Inox 316

- Chrome-nickel, austenitic AISI 316L stainless steel slats (18% Chrome - 14% Nickel - 3% Molybdenum).
- Chrome-nickel, austenitic AISI 316 stainless steel pins and guide shoes.

Model	L=Slat width		Code	Chain ref.	R=Minimum sideflexing radius	Weight per metre
	mm	"			mm	Kg/m
Flex RXM 316 Tab	82,6	3 1/4	8.33.041*	SSAA 881 T K325	457	3,10
Flex RXM 316 Tab	114,3	4 1/2	8.33.081*	SSAA 881 T K450	610	3,80
Flex RXM 316 Tab	190,5	7 1/2	8.33.111*	SSAA 881 T K750	610	5,50

\* Sizes produced only upon request. Delivery conditions and terms to be agreed.



## Flex RXMA

Carbon Steel

- Heat-treated carbon steel slats, with a surface and core hardness of 43 HRC.

- Case hardened carbon steel pins.

Model	L=Slat width		Code	Chain ref.	R=Minimum sideflexing radius	Weight per metre
	mm	"				
Flex RXMA 8°	82,6	3 1/4	8.93.040	S 881 K325	457	2,90
Flex RXMA 8°	114,3	4 1/2	8.93.080	S 881 K450	610	3,60
Flex RXMA 8°	190,5	7 1/2	8.93.110	S 881 K750	610	5,30
Flex RXMA Tab	63,5	2 1/2	8.93.021	S 881 T K250	457	2,65
Flex RXMA Tab	82,6	3 1/4	8.93.041	S 881 T K325	457	3,10
Flex RXMA Tab	114,3	4 1/2	8.93.081	S 881 T K450	610	3,80
Flex RXMA Tab	190,5	7 1/2	8.93.111	S 881 T K750	610	5,50

---

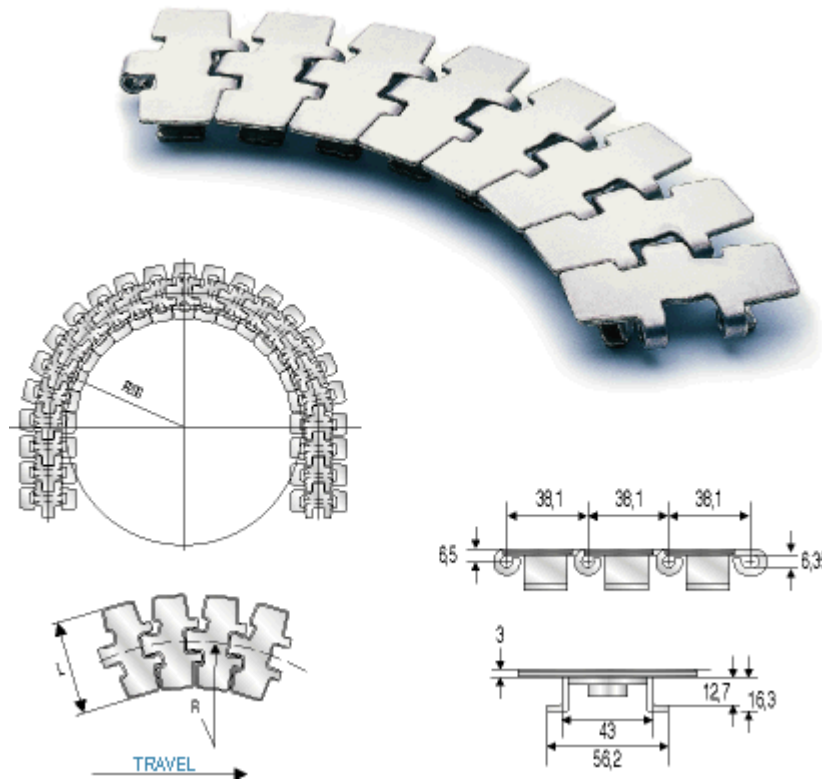

## Flex FMS2

R = 200 mm

Hard Inox

- Special, chrome-nickel, stainless steel slats, work hardened for high resistance, with shiny surface having a roughness of  $R_a < 0.3$  microns.

- Chrome-nickel, austenitic stainless steel pins and guide shoes (18% Chrome - 8% Nickel), work hardened for high resistance.

Model	L=Slat width		Code	Chain ref.	R=Minimum sideflexing radius	Weight per metre
	mm	"				
Flex FMS2 Tab	82,6	1 1/4	S.8.29.041	SSH 881 R T K325	200	3,00

---

## Flex FM2

R = 200 mm

Inox 18/8

- Chrome-nickel, austenitic AISI 304 stainless steel slats (18% Chrome - 8% Nickel), work hardened for high resistance - shiny - with a roughness of Ra < 0.5 microns.
- Chrome-nickel, austenitic stainless steel pins and guide shoes (18% Chrome - 8% Nickel), work hardened for high resistance.

Model	L=Slat width		Code	Chain ref.	R=Minimum sideflexing radius	Weight per metre
	mm	"				
Flex FM2 Tab	82,6	3 1/4	8.19.041	SSA 881 R T K325	200	3,00

---

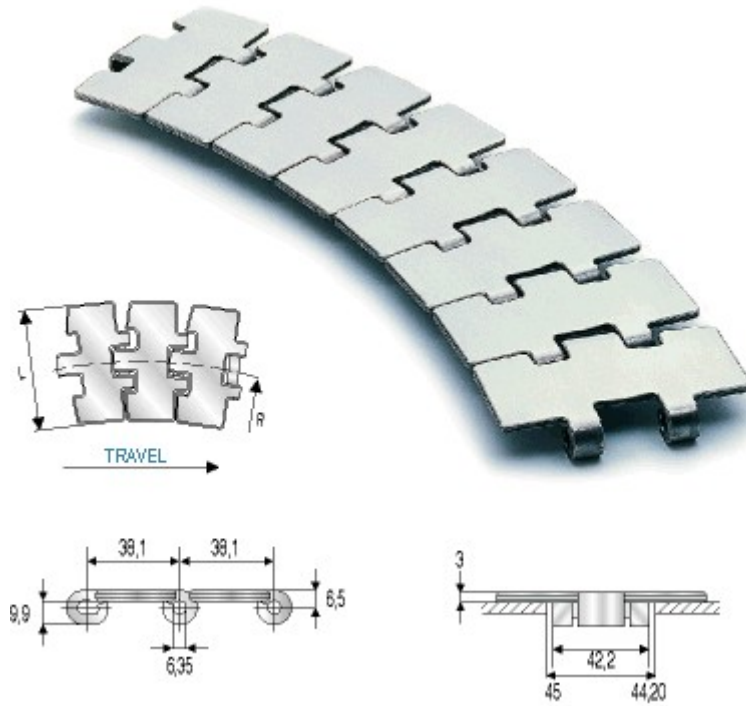

---

## New Flex Mag

### Hard Inox

- Special, chrome-nickel, stainless steel slats, work hardened for high resistance, with shiny surface having a roughness of Ra <0.3 microns.
- Special, stainless steel pins, 400 series - magnetic - work hardened for high resistance.

Model	L=Slat width		Code	Chain ref.	R=Minimum sideflexing radius	Weight per metre
	mm	"			mm	Kg/m
New Flex Mag	82,6	3 1/4	S.7.08.040	SSH 881 M K325	457	2,50
New Flex Mag	114,3	4 1/2	S.7.08.080	SSH 881 M K450	500	3,20
New Flex Mag	190,5	7 1/2	S.7.08.110	SSH 881 M K750	500	4,90

## New Flex Mag-D

### HQ Inox

- Special, new stainless steel, chrome - nickel (W.1.4589) slats - magnetic - work hardened for high resistance, with shiny surface having a roughness of Ra < 0.2 microns.
- Special, stainless steel pins, 400 series - magnetic - work hardened for high resistance.

Model	L=Slat width		Code	Chain ref.	R=Minimum sideflexing radius	Weight per metre
	mm	"			mm	Kg/m
New Flex Mag-D	82,6	3 1/4	D.7.08.040*	SSX 881 M K325	457	2,50

\* Sizes produced only upon request. Delivery conditions and terms to be agreed.

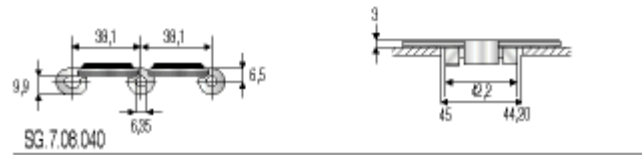
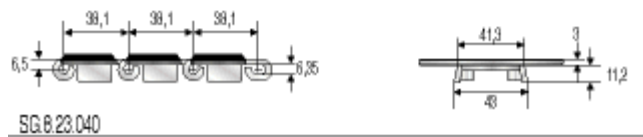
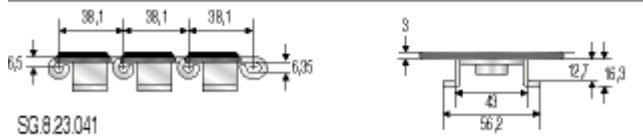
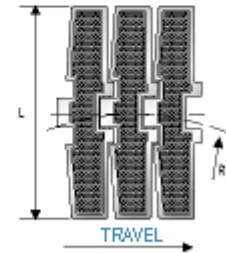
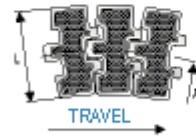
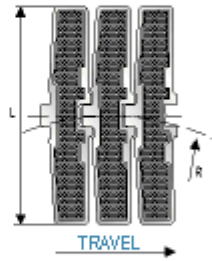

## Flex RXMS-G New Flex-G Mag

### Hard Inox

- Special, chrome-nickel, stainless steel slats, work hardened for high resistance, with a rubber insert.
- Chrome-nickel, austenitic stainless steel pins and guide shoes (18% Chrome - 8% Nickel), work hardened for high resistance (Flex RXMS-G versions).
- Special, stainless steel pins, 400 series - magnetic - work hardened for high resistance (New Flex-G Mag versions).

Model	L=Slat width		Code	Chain ref.	R=Minimum sideflexing radius	Weight per metre
	mm	"			mm	Kg/m
Flex RXMS-G 8°	82,6	3 1/4	SG.8.23.040	SSH 881 G K325	457	3,10
Flex RXMS-G 8°	114,3	4 1/2	SG.8.23.080	SSH 881 G K450	610	3,80
Flex RXMS-G 8°	190,5	7 1/2	SG.8.23.110	SSH 881 G K750	610	5,50
Flex RXMS-G Tab	82,6	3 1/4	SG.8.23.041	SSH 881 T G K325	457	3,30
Flex RXMS-G Tab	114,3	4 1/2	SG.8.23.081	SSH 881 T G K450	610	4,00
Flex RXMS-G Tab	190,5	7 1/2	SG.8.23.111	SSH 881 T G K750	610	5,70
New Flex-G Mag	82,6	3 1/4	SG.7.08.040*	SSH 881 M G K325	457	2,70
New Flex-G Mag	190,5	7 1/2	SG.7.08.110*	SSH 881 M G K750	500	5,10

\* Sizes produced only upon request. Delivery conditions and terms to be agreed.

- Flex FMS - Flex FMD - Flex FM -

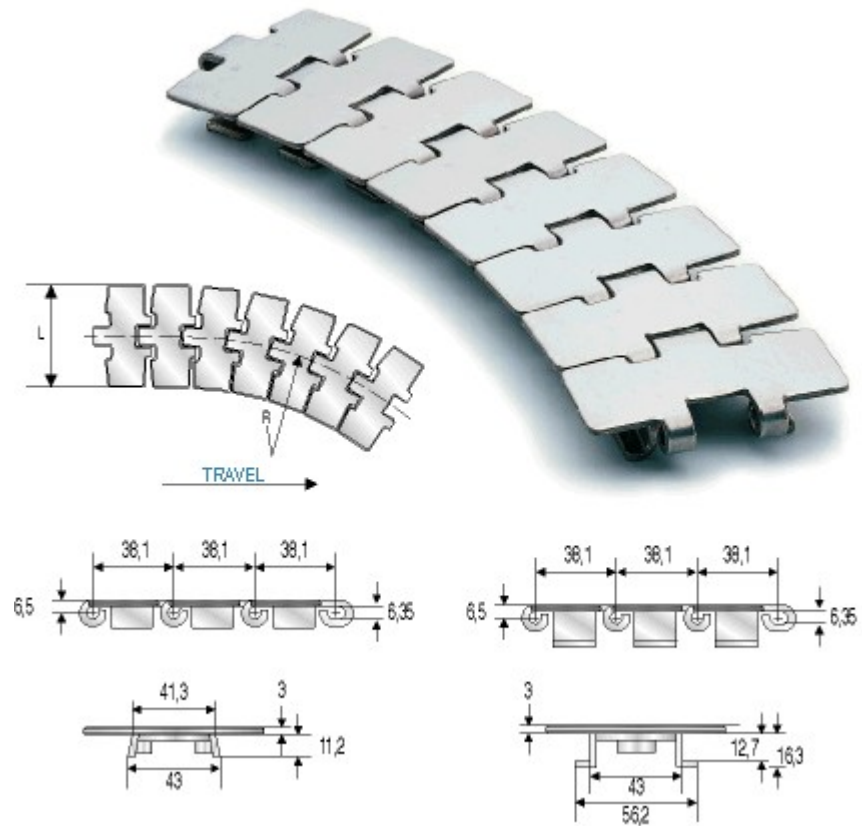

## Flex FMS

### Hard Inox

- Special, chrome-nickel, stainless steel slats, work hardened for high resistance, with shiny surface having a roughness of  $R_a < 0.3$  microns.
- Chrome-nickel, austenitic stainless steel pins and guide shoes (18% Chrome - 8% Nickel), work hardened for high resistance.

Model	L=Slat width		Code	Chain ref.	R=Minimum sideflexing radius	Weight per metre
	mm	"			mm	Kg/m
		3				
Flex FMS 8°	82,6	1/4	S.8.26.040	SSH 8811 K325	457	2,90
		3				
Flex FMS 8°	88,9	1/2	S.8.26.060	SSH 8811 K350	500	3,10
		3				
Flex FMS Tab	82,6	1/4	S.8.26.041	SSH 8811 T K325	457	3,10
		3				
Flex FMS Tab	88,9	1/2	S.8.26.061	SSH 8811 T K350	500	3,30

## Flex FMD

### HQ Inox

- Special, new stainless steel, chrome-nickel (W.1.4589) slats, work hardened for high resistance, with low surface roughness, Ra < 0.2 microns.
- Special, stainless steel pins, 400 series - magnetic - work hardened for high resistance.

Model	L=Slat width		Code	Chain ref.	R=Minimum sideflexing radius	Weight per metre
	mm	"			mm	Kg/m
		3				
Flex FMD Tab	82,6	1/4	D.8.26.041	SSX 8811 T K 325	457	3,10

## Flex FM

### Inox 18/8

- Chrome-nickel, austenitic AISI 304 stainless steel slats (18% Chrome - 8% Nickel), work hardened for high resistance - shiny - with a roughness of Ra < 0.5 microns.
- Chrome-nickel, austenitic stainless steel pins and guide shoes (18% Chrome - 8% Nickel), work hardened for high resistance.

Model	L=Slat width		Code	Chain ref.	R=Minimum sideflexing radius	Weight per metre
	mm	"			mm	Kg/m
Flex FM 8°	82,6	3 1/4	8.16.040	SSA 8811 K325	457	2,90
Flex FM 8°	88,9	3 1/2	8.16.060	SSA 8811 K350	500	3,10
Flex FM Tab	82,6	3 1/4	8.16.041	SSA 8811 T K325	457	3,10
Flex FM Tab	88,9	3 1/2	8.16.061	SSA 8811 T K350	500	3,30

- Super - Super-G -

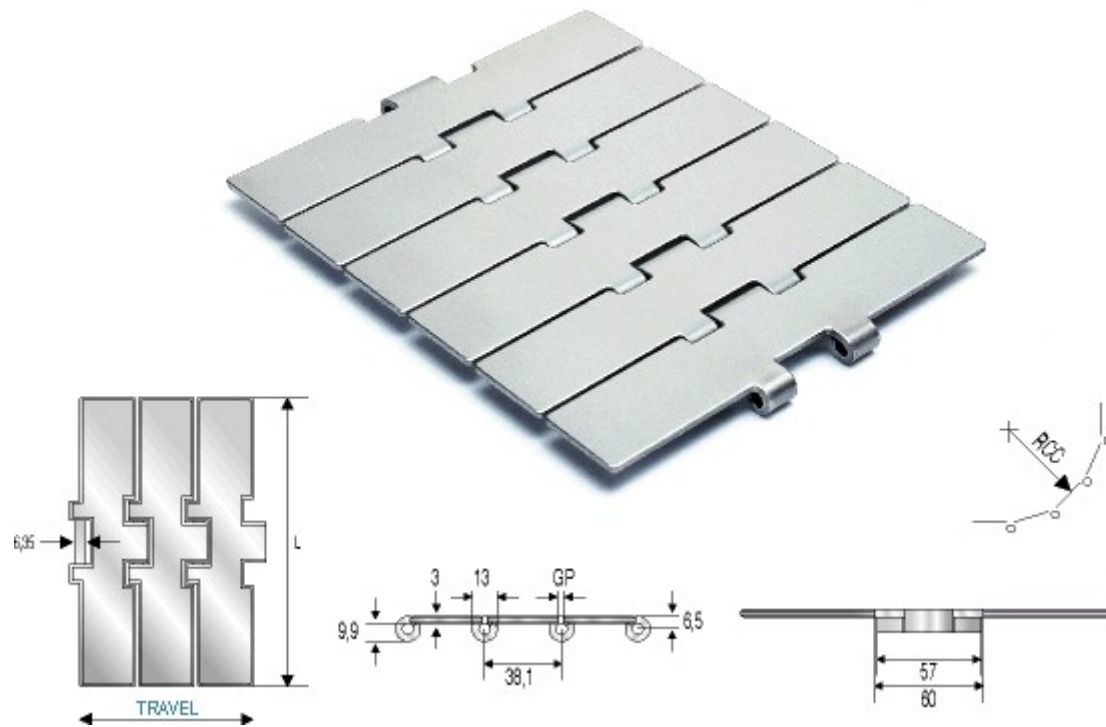

## Super Hard Inox

- Special, chrome-nickel, stainless steel, slats, work hardened for high resistance, with shiny surface having a roughness of  $R_a < 0.3$  microns.

- Chrome-nickel, austenitic stainless steel pins (18% Chrome - 8% Nickel), work hardened for high resistance.

Model	L=Slat width		Code	Chain ref.	Hardness	GP	RCC	Weight per metre
	mm	"			HRC	mm	mm	Kg/m
Super	190,5	7 1/2	S.7.00.175	SSH 8127 K750	30	1,6	150	5,10

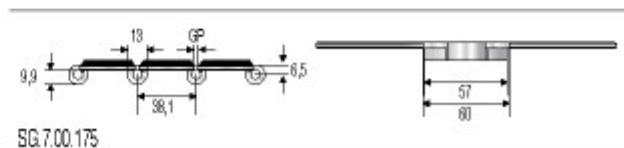
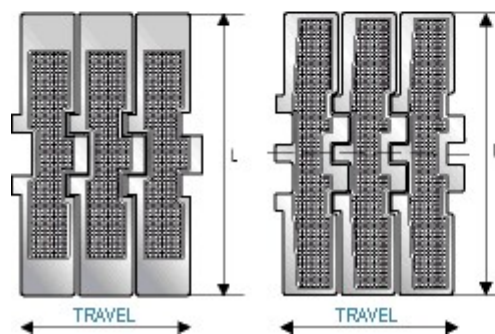

## Super-G

Hard Inox

- Special, chrome-nickel, stainless steel slats, work hardened for high resistance, with a rubber insert.
- Chrome-nickel, austenitic stainless steel pins and guide shoes (18% Chrome - 8% Nickel), work hardened for high resistance.

Model	L=Slat width		Code	Chain ref.	Hardness	GP	RCC	Weight per metre
	mm	"						
Super-G	190,5	7 1/2	SG.7.00.175	SSH 8127 G K750	30	1,6	150	5,35

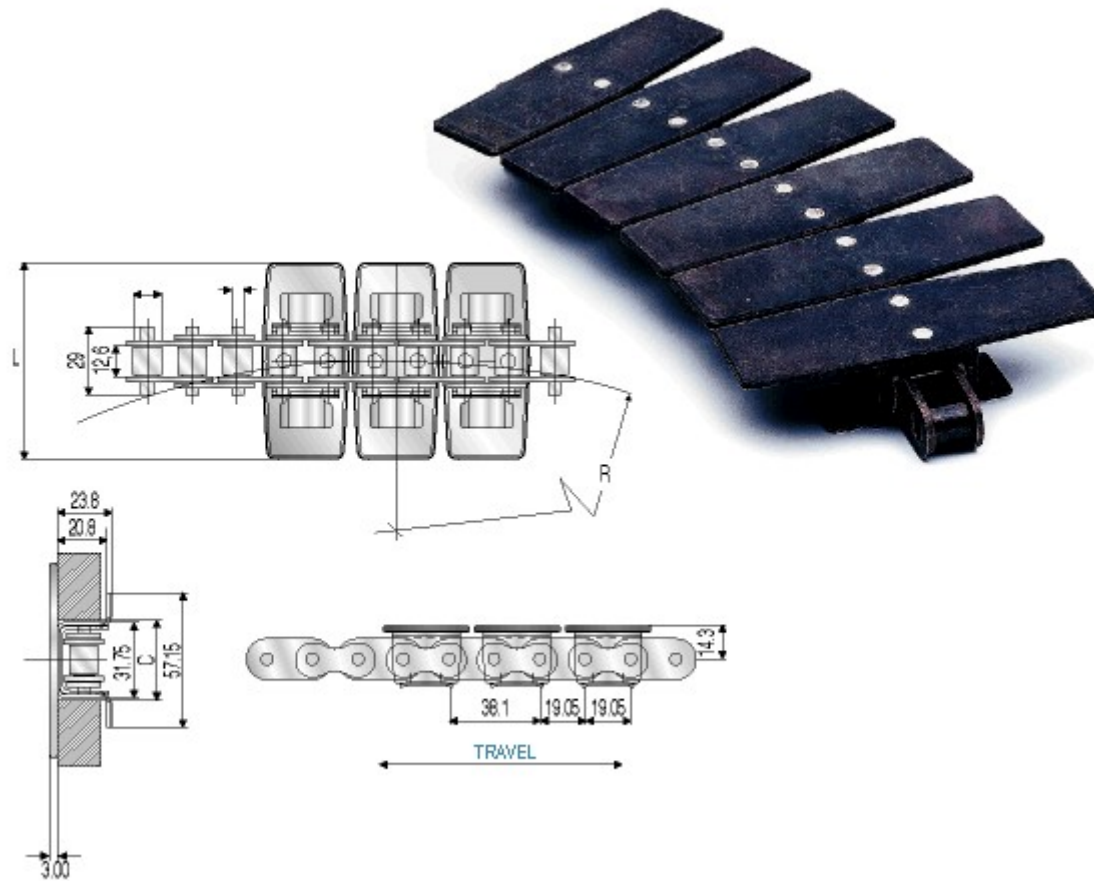

---

1874

- This high speed, high capacity series offers better efficiency and reliability in applications where high temperatures or abrasive materials are involved.
- Sideflexing: steel and stainless steel top plates, 19,05 mm - 3/4" pitch.

Code	Chain ref.	Ultimate strength	Base chain material	Top plate material	L= Slat width	Straight C	Curve C	R= Minimum sideflexing radius	Weight per metre					
		N			mm	mm	mm	mm	Kg/m					
1874.CC.041	1874	27000	Steel	Steel	82,6	34,1	34,6	356	4,20					
	K325				114,3			356	4,80					
1874.CC.081	1874				152,4			457	5,70					
	K450													
1874.CC.101	1874													
	K600				190,5			610	6,40					
1874.CC.111	1874													
	K750													
1874.CS.041	1874 A				27000			Steel	Stainless Steel	82,6	34,1	34,6	356	4,20
	K325									114,3			356	4,80
1874.CS.081	1874 A	152,4	457	5,70										
	K450													
1874.CS.101	1874 A													
	K600	190,5	610	6,40										
1874.CS.111	1874 A													
	K750													
1874.SS.041	1874					82,6							356	4,20
	SS					114,3							356	4,80
	K325				152,4			457	5,70					

