

# Innopal

Palletizing Robots for Non-Returnables

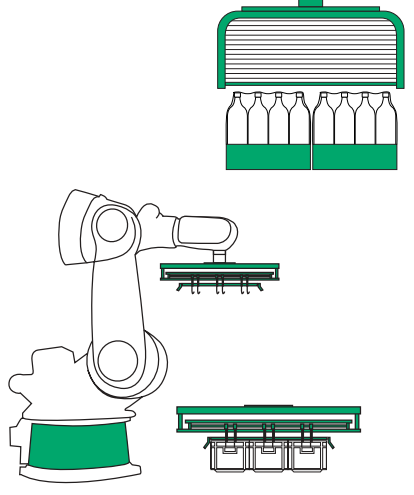

Modular, Versatile, Highly Productive, and Future-Safe –  
The Compelling New Generation of KHS Palletizing Robots



■ <b>Innopal Palletizing Robot –</b> A Name for an Advanced Generation of Machines	4
■ <b>Innopal PBL Palletizing Robot –</b> The “Little One” with High Palletizing Capacity	6
■ <b>Innopal PBN Palletizing Robot –</b> The Base Robot for Three Capacity Models	8
■ <b>Innopal PBN Palletizing Robot –</b> Three Models with Many Advantages	10
■ <b>Innopal PBH Palletizing Robot –</b> For Your Capacity Range up to 380 Layers per Hour	12
■ <b>Innopal PBHS Palletizing Robot –</b> For Your Capacity Range up to 600 Layers per Hour	14
■ <b>Innopal RS 3 Single-column Robot</b> For Load Capacities up to 500 kg and Capacity Ranges up to 520 Layers per Hour	16
■ <b>Innopal RK Articulated-arm Robot –</b> For Load Capacities up to 210 kg, 360 kg, and 570 kg	18
■ <b>Innopal HR Handling Robot –</b> Liner Inserter as Extra Equipment	20
■ <b>Moveable, Additional Centering –</b> Safety for Pallet Stacking	22
■ <b>Inline Grouping Station –</b> Carrier Plate Distributor, the Perfect Continuous Pack Infeed to Your Palletizing Robot	24
■ <b>Innopal Grouping Station –</b> Precision “Templates” for Your Palletizing Robot	26
■ <b>Innopal ASH Depalletizing Robot –</b> For Fully Automatic Infeed of Your New Containers to the Processing Operation	28
■ <b>Innopal ASN Depalletizing Robot –</b> Infeed Your New Containers to the Processing Operation Always at the Right Level	30



# Innapal Palletizing Robots – A Name for an Advanced Generation of Machines

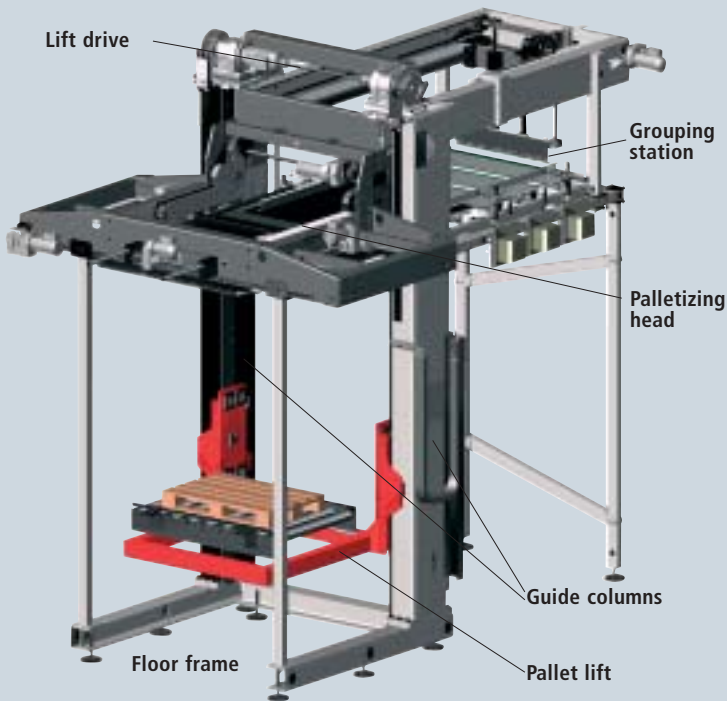

Modular design assembly

The new-generation KHS palletizers are modular design machines operated by robot technology. This is why we call them "palletizing robots".

A new drive concept was developed with key features such as servomotors, toothed belts, and continuous-path control.

The overall concept consistently meets all market demands for:

- High flexibility  
Product conversion and changeover easily carried out during production operation.
- Great reliability  
High-availability palletizing robots operate dependably and handle products exceptionally gently in three-shift operation.

- Ease of maintenance  
Standardized operating for all machines.  
Ergonomically perfect.  
Control panels with large-size graphical user interfaces.

- Environmental soundness  
Low power, water, and air consumption, small footprint, and overall low-noise operation.

For implementation, this means specifically:

- Identical, interchangeable modules such as guide columns, floor frames, lift drives.  
Reduction of the assortment of parts to thus cut the cost of spare part stockkeeping.
- Standardized modular drive technology for all machines.  
Servodrives. Coordinated control of axis movement.  
Absolute drive position sensing system.  
Highly dynamic, sequence of motion optimally matched directly to the product; position accuracy of  $\pm 0.5$  mm.

Toothed belt lift drive



The KHS central control concept ensures maximum line efficiency

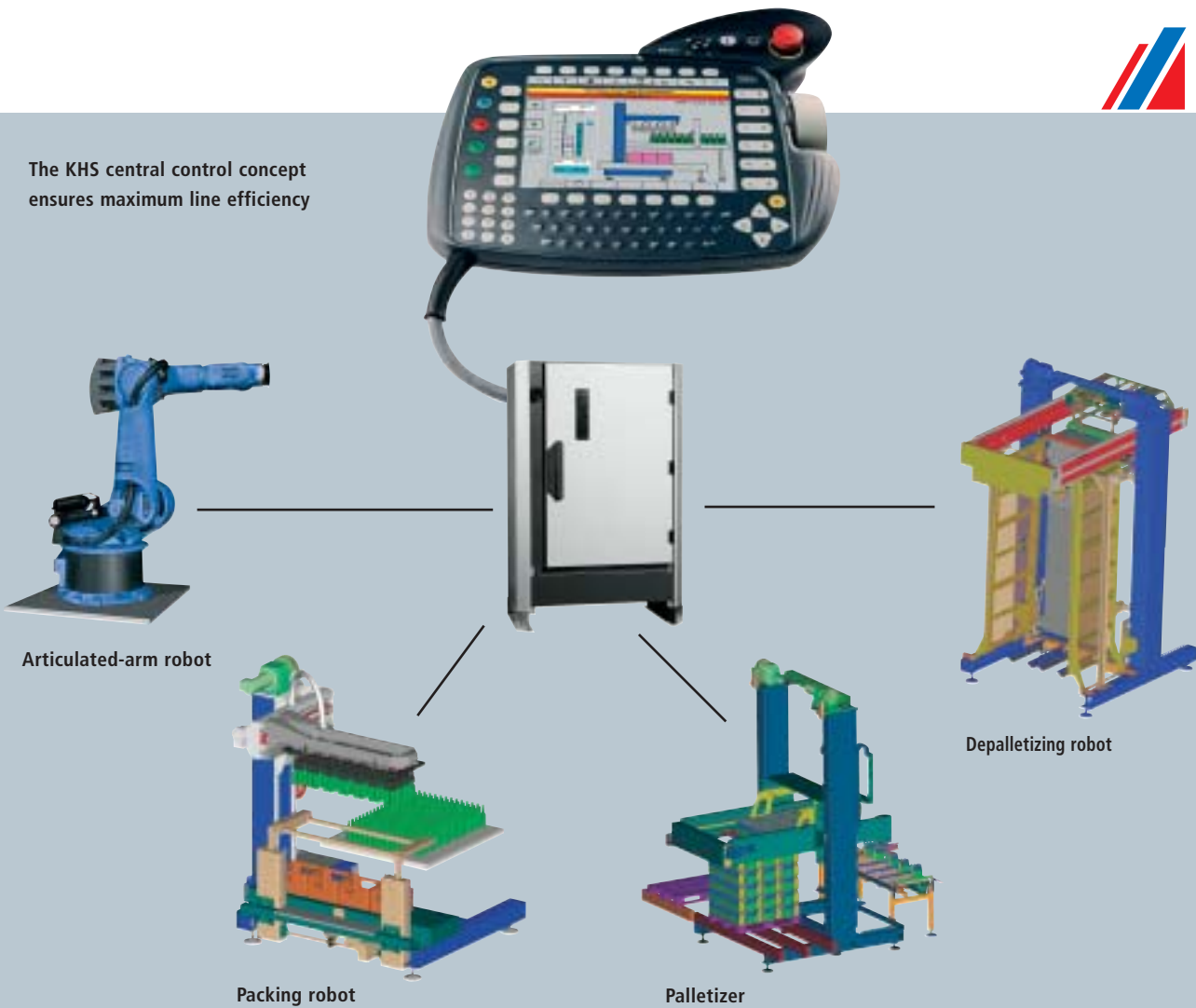

- A typical characteristic of the KHS PC-based robot control:  
Only one intelligence that controls everything!  
**No more interface problems.**
- Use of heavy-duty toothed belt drives.  
**Smooth operation, minimum wear, low-cost servicing, and maintenance.**
- All product-contacting machine parts are plastic-covered  
**High product assurance and gentlest possible handling of the goods to be processed.**
- Extensive use of bus technology  
**Less wiring.**

- Integration of Soft PLC and visualization  
**Prerequisite for easy and safe operating.**
- Consistent use of plug-and-socket components  
**Plug & Play technology in servo control cabinets for simplified handling. Saves time and work.**
- Direct Teleservice via modem or LAN  
**Direct service capabilities for greater reliability. Simplified troubleshooting.**

## Innopal PBL Palletizing Robot – The “Little One” with High Palletizing Capacity



Internal turning device

- Innopal PBL with height control – the inexpensive palletizing solution for the low and medium capacity range.

**Tailored to the needs of medium-size businesses.**

- Compact modular design system.

Combined layer and row pusher.

**No grouping station necessary.**

**Requires considerably less space.**

- The packs are pushed from the infeed roller conveyor onto the loading plate and from there onto the pallet.

**Simple, reliable technology.**

Palletizing station





Frequency controlled infeed roller conveyor

- Programmable robot axes  
 Reliable processing of all standard palletizing tasks.
  
- Palletizable range of products:  
 Plastic beverage crates, cartons, trays, shrink-wrapped packs, individual small packages, bags.



Combined pusher

#### Technical Specifications

Machine speed	1,800 packs per hour
Maximum pallet height	2,500 mm
Pallet dimensions	750 to 1,300 mm (across and in direction of palletizing)



## Innopal PBN Palletizing Robot – The Base Robot for Three Capacity Models



- Innopal PBN 1 with height control and automatic layer formation from individual packs. Palletizing on one pallet. Up to 350 layers per hour.

**Wide range of uses coupled with high availability.**

- Innopal PBN 1-2 with height control, fully automatic layer formation, widened shuttle car, and wider loading plate. This makes it possible to palletize two pallets positioned side by side simultaneously.

**This means: Twice the number of layers at only a slightly higher cost of investment!**

**Ideal for maximum palletizing performance.**

**Up to 700 layers per hour.**

- Innopal PBN 2 with permanent two-pallet palletizing.

**Up to 700 layers per hour.**

**High capacity palletizing, particularly for Europallet processing.**

Palletizing process at the Innopal PBN 1

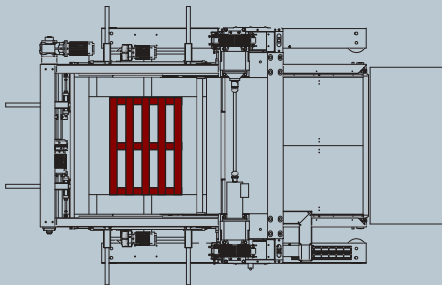

#### Innopal PBN 1 technical data

Machine speed	300 layers per hour, pack infeed at bottom
	350 layers per hour, pack infeed at top
Maximum pallet height	2,500 mm
Pallet dimensions	750 to 1,300 mm (across and in direction of palletizing)

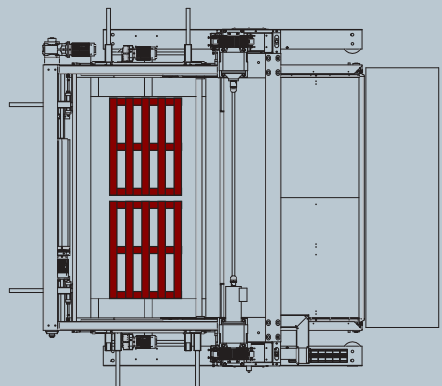

#### Innopal PBN 1-2 technical data

Machine speed	600 layers per hour, pack infeed at bottom
	700 layers per hour, pack infeed at top
Maximum pallet height	2,500 mm
Pallet dimensions	750 to 1,300 mm (in direction of palletizing)
	1,500 to 2,400 mm (across direction of palletizing)

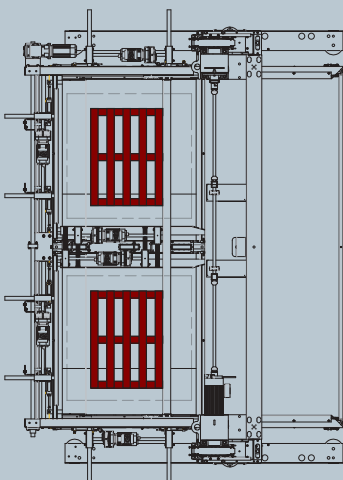

#### Innopal PBN 2 technical data

Machine speed	600 layers per hour, pack infeed at bottom
	700 layers per hour, pack infeed at top
Maximum pallet height	2,500 mm
Pallet dimensions	750 to 1,300 mm (in direction of palletizing)
	1,500 to 2,400 mm (across direction of palletizing)

## Innapal PBN Palletizing Robot – Three Models with Many Advantages



Innapal PBN palletizing robot with grouping station

- Single or multiple lane pack infeeds, variable pack infeed heights, variable layer formation setup.  
**Greater flexibility in solving your palletizing tasks.**
- Each layer is exactly centered automatically prior to discharge.  
**The result: Perfect layer formations, gentle-to-product handling, and high overall stability of the pallet load.**
- Capabilities for fully automatic layer changeover as well as plastic crate processing.  
**This saves time when changing products and increases the machine availability.**

Innapal PBN 1 processing half pallets with a handling robot for inserted liners





Innopal PBN 1-2 palletizing robot

- Simple adaptation to various pallet formats.  
Enables you to process virtually all pallet sizes.
- The palletizing robot can be equipped with a robot-model liner inserter.  
Palletizing with and without inserted liners.  
Palletizing is not delayed by inserted liner processing.
- Palletizable product line:  
Plastic beverage crates, cartons, trays, shrink-wrapped packs, individual small packages, bags.

Motor-driven layer centering



Innopal

# Innopal PBH Palletizing Robot – For Your Capacity Range up to 380 Layers per Hour

- Innopal PBH – single-station palletizing robot equipped with pallet lift and elevated pack infeed.  
**Pallet heights up to 2700 mm are possible.**  
**More layers per pallet.**
- One or multiple lane pack infeeds, variable fully automatic layer formation setup.  
**Flexibility that enables you to solve your palletizing tasks perfectly.**
- Compact modular design system.  
**Requires considerably less space.**
- The lifting unit and loading station operate with servo technology and toothed belt drives.  
**This means: Great reliability, high machine availability, nearly no servicing effort.**
- Capabilities for fully automatic layer changeover and plastic crate processing.  
**This saves time when changing products and increases efficiency.**
- The pallet lift travels to the loading position while the loading plate picks up the layer.  
**Teamwork for higher performance**

Innopal PBH grouping station

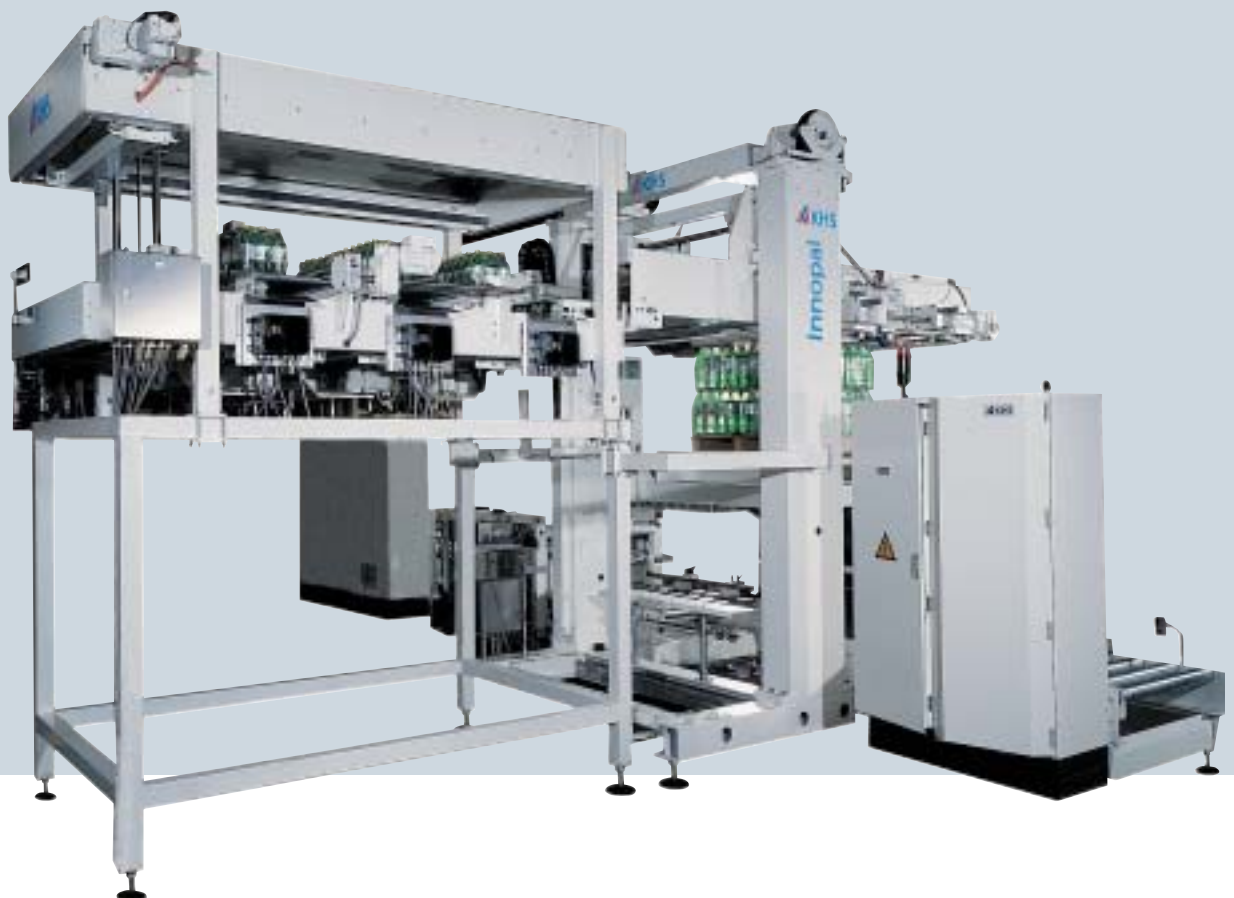



Pallet lift to the top loading position

- Palletizing with and without inserted liners possible. Can be optionally equipped with a handling robot. **The optimum solution for all capacity ranges.**
- Each layer is exactly centered automatically prior to discharge. **Ensures perfect layer formations with gentle-to-product handling and high overall stability of the pallet load.**
- Simple adaptation to various pallet formats. **This increases the versatility of your line.**
- Palletizable product line: **Plastic beverage crates, cartons, trays, shrink-wrapped packs, individual small packages, bags.**

#### Technical Specifications

Machine speed	380 layers per hour, pack infeed at top
Maximum pallet height	2,700 mm
Pallet dimensions	750 to 1,300 mm (across and in direction of palletizing)

# Innapal PBHS Palletizing Robot – For Your Capacity Range up to 600 Layers per Hour



The Innopal PBHS palletizing complex layer patterns

- Innopal PBHS – single-station palletizing robot equipped with pallet lift, elevated pack infeed, and two-piece pusher plate.  
**Variety of capabilities for integration in all tailored palletizing systems.**

- Single or multiple lane pack infeeds, variable fully automatic layer formation setup.  
**Flexibility that enables you to solve all palletizing tasks perfectly.**

- Each half of the two-piece loading plate is pulled out from under the layer from the left and right.  
**Half the pushoff distance saves the time required for each cycle and increases overall performance.**

- All standard-width InnoLine roller conveyors and chain segments or InnoLine turning segments can be mounted as pallet carriers on the lifting frame.  
**This enables conveying lengthwise or crosswise to the direction of palletizing and perfect adaptation to prevailing local conditions.**

- The lifting unit and loading station operate with servo technology and toothed belt drives.  
**This means: Great reliability, high machine availability, minimum servicing effort.**

Inserting inserted liners





Grouping station row pusher

- Capabilities for fully automatic layer changeover and plastic crate processing.  
**Time-saving product changeover and thus higher efficiency.**
- Each layer is exactly centered automatically prior to discharge to the pushoff station.  
**This ensures perfect layer formations with gentle-to-product handling and high overall stability of the pallet load.**
- Palletizing with and without inserted liners possible. Can be optionally equipped with a handling robot on request.  
**Perfect adaptation to all required palletizing capacities.**
- Simple adaptation to various pallet formats.  
**Even more flexibility.**
- PBHS palletizing robot – the palletizer optionally equipped with separate empty pallet infeed and an integrated empty pallet magazine.  
**Time-saving empty pallet infeed; high layer output right down the line.**
- Palletizable products:  
**Plastic beverage crates, cartons, trays, shrink-wrapped packs, individual small packages, bags.**



# Innopal

### Technical Specifications

Innopal PBHS machine speed	420 layers per hour, pack infeed at top
Machine speed of Innopal PBHS equipped with separate pallet infeed	600 layers per hour, pack infeed at top
Maximum pallet height	2,500 mm
Pallet dimensions	750 to 1,300 mm (across and in direction of palletizing)

## Innopal RS 3 Single-column Robot – For Load Capacities up to 500 kg and Capacity Ranges up to 520 Layers per Hour

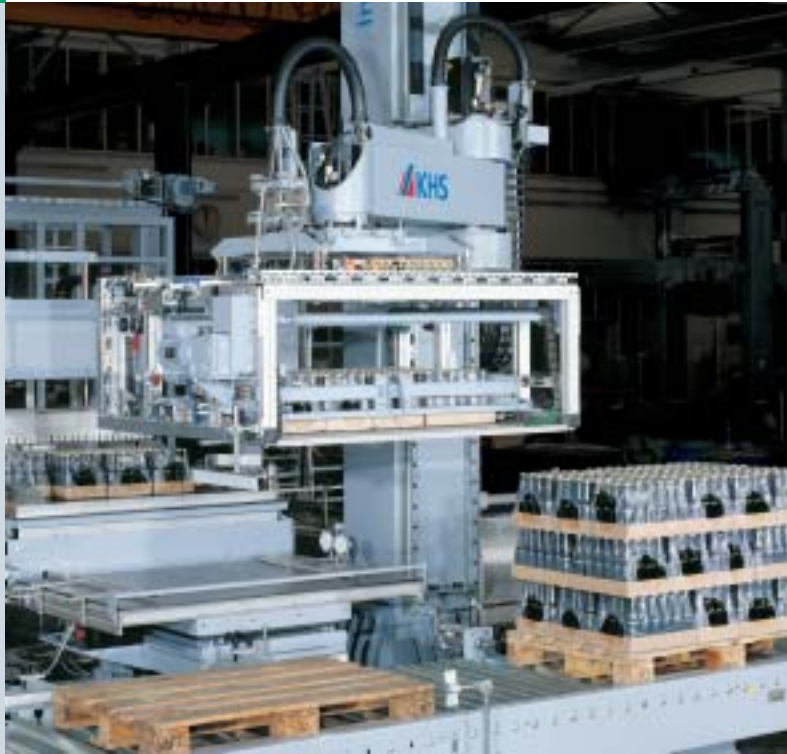

Roller carpet at the Innopal RS 3

- Innopal RS 3 – multiple-station palletizing robot with a 180-degree working radius.  
**For you this means: A wide variety of variants and uses, higher output, and greater flexibility within a small amount of space.**
- Modular drive technology used such as maintenance-free, highly dynamic servomotors and low-noise toothed belts.  
**Shorter cycle times, reduced wear, and less servicing effort.**
- The three-axis device can be easily reprogrammed.  
**Gives you an increased degree of freedom, greater flexibility, and optimal capabilities for adaptation to specific palletizing tasks.**

Innopal RS3 also prepared for processing returnables by means of a low-level preparation table





Four-sided centering of the last layer while pulling out the roller carpet



- Layers are palletized by a shutter-type gripper head. This offers you gentle and reliable product handling even in the high performance range.
- When a new layer is placed on the pallet, each new layer is centered and held in place by a frame at the bottom of the gripper head. This ensures that the entire pallet load is securely stacked.
- Inserted liners can be easily inserted by an optionally available handling robot. The best solution for all task definitions.
- The control is modular in design. Braking energy recovery, time tagging, and ASI bus technology. This increases reliability and saves reference travel.
- Greatly reduced number of external sensors. You benefit from fewer spare parts, increased operational safety, decreased operating costs, and higher line efficiency.
- Can be equipped with additional gripper heads. Optional capabilities for automatic gripper head changing. Providing the flexibility necessary to palletize a widest possible range of products.
- Palletizable products: Shrink-wrapped packs, cartons, trays, packages.

#### Technical Specifications

Machine speed	520 layers per hour
Load capacity	500 kg
Maximum pallet height	2,500 mm
Pallet dimensions	400 to 1,300 mm (across and in direction of palletizing)

# Innopal RK Articulated-arm Robot – For Loads up to 210 kg, 360 kg, and 570 kg

- Innopack RK – single-station, articulated-arm model palletizing robot. Can be converted and used for many other packing and palletizing tasks.  
**Great application flexibility, highly assured return on investment.**
- Multi-axis controlled articulated-arm robot with a large 360-degree working radius.  
**Total freedom of movement. No “blind spots”!  
Provides you greater project planning flexibility.**
- Use of ultra-modern robot technology.  
For you this means:
  - **Highly dynamic, maintenance-free servomotors**
  - **High performance**
  - **Less space due to fewer peripherals in the surrounding area**
  - **Saves the cost of additional conveying systems**
- The robot is programmable.  
**Virtually all sequences of motion are programmable.  
The result: Maximum flexibility of use and greater assurance for solving future palletizing tasks.**
- High-resolution absolute encoders ensure precise positioning and exact reproducibility.  
**Ideal for palletizing a widest possible range of products and layer patterns.**
- The control is modular in design.  
Braking energy recovery, absolute encoders, and bus technology.  
**This increases reliability and saves reference travel.**

Innopal RK with roller carpet and Innopal RSZ column-type centering





- Shutter-type gripper heads move packs layer by layer.  
**An efficient, reliable method of operation.**
  
- The robot can also be equipped with other gripper head models instead of the shutter-type.  
 Optional automatic gripper head changing.  
**Enables you to increase application flexibility, save time and work.**
  
- Palletizable products:  
**Shrink-wrapped packs, cartons, trays, packages.**



Highly flexible combined packer/palletizer for processing displays

Technical Specifications	Innopal RK 4-180	Innopal RK 6-350	Innopal RK 6-500
Load capacity	210 kg	360 kg	570 kg
Machine speed	520 cycles per hour	425 cycles per hour	380 cycles per hour
Maximum pallet height	2,500 mm		
Pallet dimensions	400 to 1,300 mm (across and in direction of palletizing)		

## Innopal HR Handling Robots – Liner Inserter as Extra Equipment



Free-standing handling robot at a depalletizer equipped with height control

- Safe stacking of soft packs on pallets requires inserted liners, inverted trays, cover frames. The Innopal HR handling robot is the ideal accessory for depalletizing these palletizing aids.

**Fast and reliable removal of inserted liners and palletizing aids.**

**Sorted placement in corresponding magazine in a preprogrammed depalletizing rhythm.**

**High positioning accuracy.**

- Compact modular design system.

**The perfect enhancement to all Innopal palletizing robots.**

Integrated Innopal HR handling robot



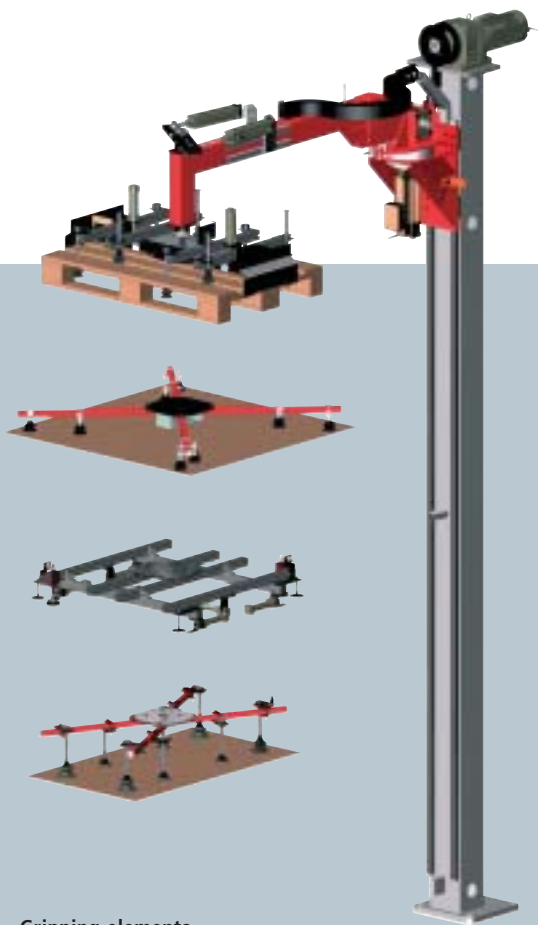

Gripping elements

- Range of products for processing:  
 Inserted liners made of plastic, cardboard, etc.  
 Inverted trays  
 Inverted tray bases  
 Pallets (all types)  
 Cover frames

- Various gripping elements can be used. For inserted liners, pallets, cover frames.  
**Flexibility that enables you to meet a widest possible variety of processing specifications.**
- Can also be equipped with two additional pallet gripper arms.  
**This enables you to process two half pallets simultaneously.**
- Pneumatic suction-cup grippers for inserted liners.  
**Reliable, exact mode of operation even in the high performance range.**
- Toothed belt drive.  
**Great reliability, low wear, reduced servicing effort.**
- Precision linear guidance  
**Low-noise operation, lubricated for life.**

#### Technical Specifications

Maximum vertical travel	2,610 mm
Load for swivel arm with vacuum gripper	Depends on inserted liner surfaces
Load for swivel arm with pallet gripper	50 kg

## Moveable, Additional Centering – Safety for Pallet Stacking



Innopal RSZ robot centering

Two different types of moveable centering units are available for selection:

1. Innopal RSZ centering robot with its own single-column guidance.

Versatile, can be optimally integrated in any system, combinable with the Innopal HR handling robot for inserted liner handling.

2. Innopal PZ two-column model, gantry-type centering.

Not quite as versatile but for that a less expensive version.

Innopal RSZ together with an Innopal RK palletizing robot





Innopal RS 3 aided by gantry-type centering

- An additionally liftable frame holds the top layer of each pallet in position.  
**A safe basis for placement of the following layer.**
- Perfect press-in of inserted liners such as cardboard blanks.  
**Complete pallet stability. No protrusions to damage load-securing stretch wrappers.**
- The centering operates in a preprogrammed palletizing rhythm.  
**Extremely high palletizing precision of the entire pallet stack.**
- Compact modular design system.  
**Space-saving design for variable use in your line.**
- Toothed belt lifter drive.  
**Nearly no wear, no noise, minimum servicing, high machine availability.**
- Implementation of the new robot technology.  
**Exact centering position.**

## Inline Grouping Station –

# Carrier Plate Distributor, the Perfect Continuous Pack Infeed to Your Palletizing Robot



Line distributor

- New type of line distributor for non-returns from one to an infinite number of lanes to set up layers for the palletizing robot.  
**This allows users to quickly and reliably set up a wide range of different layer patterns.**

- The packs are rotated inline by mat chains running at different speeds. The chains are arranged at a special angle to the longitudinal axis in relation to each other.

**This means short travel and exact pack rotation.**

- Each of the run-outs is equipped with a servo drive installed transversally to the direction of rotation enabling modification of the discharge station for individual packs.

**Capable of forming virtually all layer patterns.**

- A newly developed, motor-driven knife-edge belt provides optimum pack transition points from the distributor to the turning mechanism.

**Even the smallest non-returnable packs remain stable at the transition points.**

Infeed to the turning facilities





- Powered by high-performance toothed belt technology.  
Prerequisite for close carrier plate pitch.  
**High layer stability of the packs, low-wear and low-noise operation, reduced servicing.**
- No mechanical handling of no-return packs  
**Gentle-to-product pack handling.**
- Automatic changeover to a widest possible variety of different layer formations.  
**Great flexibility and noticeable time-savings.**
- Pack counting maintains steady pack infeed.  
One layer formation is completed when temporary stops occur.  
**No manual intervention required.**
- Grouping station equipped with continuous chain mat and traveling side centering.  
**Reliable, gentle-to-product layer grouping ready for pickup by the layer pusher of the palletizing robot.**
- Precision guidance of the group formation in the grouping station.  
**Maximum reproducing precision.**
- Other advantages:  
**Bus technology and frequency-controlled drives.**
- Processable product line:

  - No-return packs, film-wrapped packs, cartons, trays, wrap-around cartons.
  - Can be used for Innopal BH and BHS palletizing robots
- Performance data:

  - The output always depends on the size of the packs.
  - The maximum pack-to-pack feed speed ahead of the line distributor is approximately 0.6 meters per second, single-lane lengthwise.

#### Technical Specifications

Standard pack infeed	Lengthwise (contact Engineering Dept. for crosswise infeed)
Formation of layers on grouping table	Lengthwise
Rows per layer	Four rows can be processed (standard) Five, depending on the pattern (contact Engineering Dept.)

## Innapal Grouping Station – Precision “Templates” for Your Palletizing Robot



Dual-lane grouping station

- Compact modular design system.  
Reliable engineering, high machine availability,  
space-saving.
- Infeed roller conveyor with attached turning device, row  
stopper, sectional switch-off, and move-up table.  
Free choice of layer patterns.
- Row pusher and move-up table run at the same speed.  
Packs are handled gently when pushed onto the  
loading plate.
- Robot technology, programmable robot axes  
Precise positioning and exact reproducibility.
- Bus technology  
Less cabling effort.
- Toothed belts and servo drives  
Low noise level, little wear, reduced servicing effort.

Grouping station with low-level infeed to an Innapal PBN palletizer



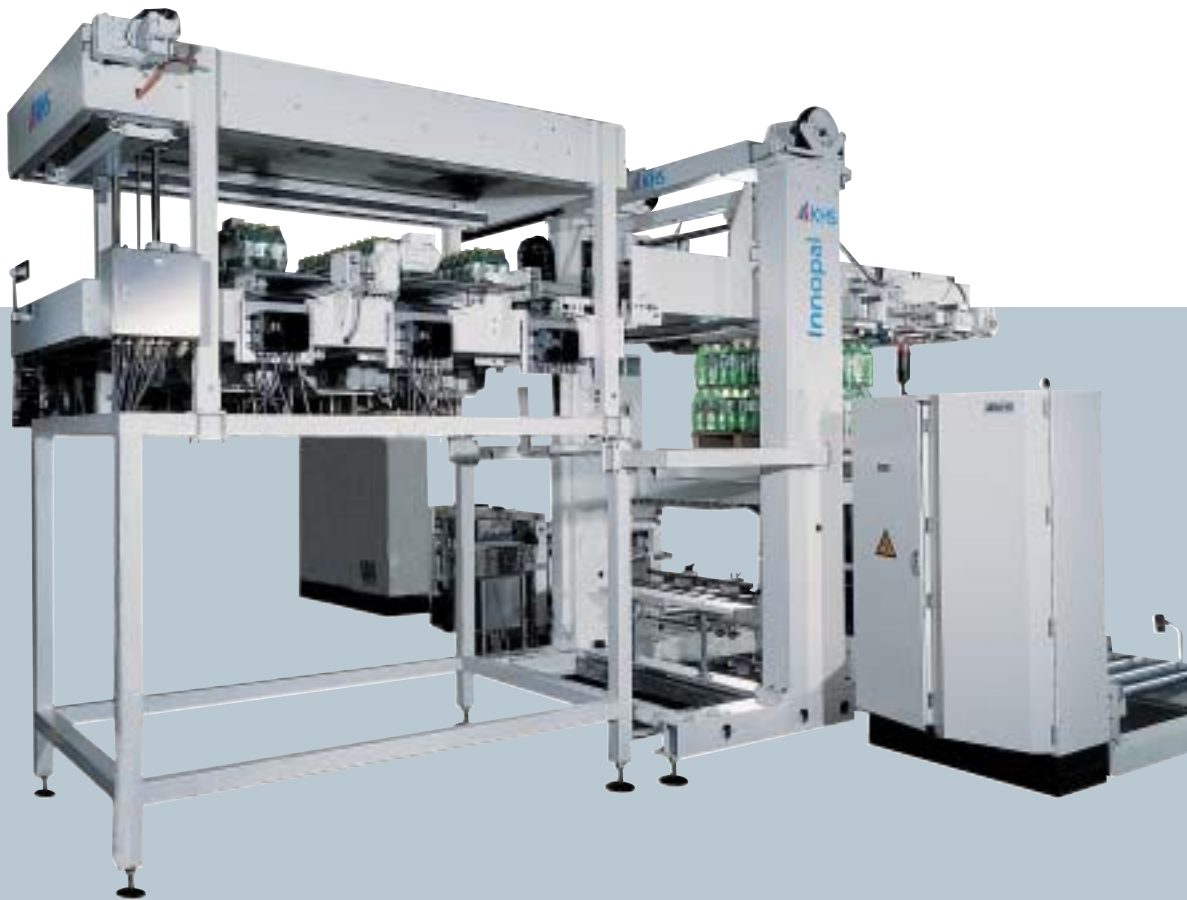

Grouping station with elevated infeed to an Innopal PBH palletizer

■ Pack infeed over one or more lanes possible.

Flexibility in pallet capacity layout and optimum capabilities for adaptation to a widest possible variety of palletizing tasks.

■ Processable product line:

Plastic beverage crates, cartons, trays, shrink-wrapped packs, individual small packages, bags.

#### Examples of pack formations

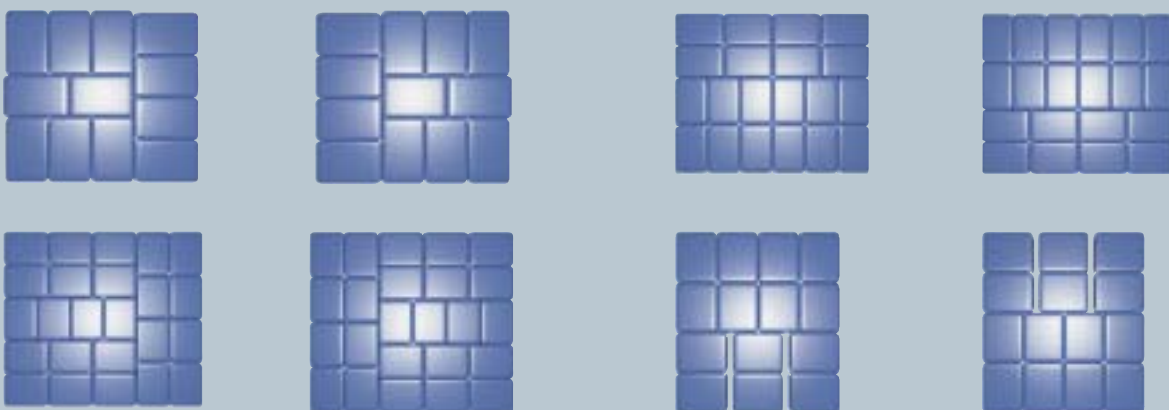

#### Technical Specifications

Machine speed	According to the speed of the palletizer downstream.
Maximum layer height	455 mm
Layer width	750 to 1,300 mm (across direction of push) 750 x 1,300 mm (across direction of push)

# Innapal ASH Depalletizing Robots – For Fully Automatic Infeed of Your New Containers to the Processing Operation



Pushoff carriage with new glass

- Servo technology and toothed belts used to drive the pushoff carriage.

A low-noise, low-wear method requiring less servicing.

- All product-contacting surfaces covered with plastic.

Ensures gentle handling of new containers.

- Innapal ASH depalletizing robots including the inserted liner and frame removers, pallet lift, and pallet conveyor operate fully automatically. Equipped with state-of-the-art robotics and ASI bus system.

**Your benefit: Simple cabling and transparent installation.**

- Exact pallet centering by means of adjustable well walls on the left and right.

**Reliable pallet position fixing in the well directly below the pushoff carriage. Reliable, gentle depalletizing of new containers; no danger of collapse during the entire depalletizing process.**

- Each layer to be depalletized is centered by a four-sided pushoff carriage.

**Prerequisite for safe high-speed depalletizing down to the last layer.**



Lift well with three-sided centering



Pallet lift with partially depalletized new glass pallet



Inserted liner and inverted tray processing



- The inserted liners are held in place by grippers during the pushoff process.

**The result: Reliable container pushoff.**

**The inserted liner remains in place.**

- Simple adaptation to various pallet formats.  
**This increases the versatility of your line.**

- Reliable processing of various container heights and diameters.  
**Saves you the cost of investment in expensive extra equipment.**

- Belt or chain mat discharge of containers.  
**Highly efficient conveying technology**

- Wood and steel frames are removed separately and placed in special magazines.  
**Perfect disposal of packing aids ensures uninterrupted, time-saving depalletizing without the need of operator intervention.**

- Product range for depalletizing:  
**New glass containers, PET containers, cans.**  
**Maximum container height: 400 mm.**

#### Technical Specifications

Handling robot in the machine	280 layers per hour, PET 300 layers per hour, glass
Handling robot and frame remover	400 layers per hour, cans
Maximum pallet height	2,600 mm
Pallet dimensions	750 to 1,300 mm in direction of discharge 750 to 1,250 mm across direction of discharge

## Innapal ASN Depalletizing Robots – Infeed Your New Containers to the Processing Operation Always at the Right Level



Pushoff carriage with new glass

- Innapal ASN depalletizing robots including height control, inverted tray and inserted liner removers operate fully automatically. Equipped with state-of-the-art robotics and ASI bus system.  
**Complete task program processing within a restricted amount of space. Simple cabling and transparent installation.**

- Infinitely variable discharge height for new containers. Any height is possible.  
**Enabling you to meet all individual requirements of your line.**
- Exact pallet centering by means of adjustable centering on the left and right sides.  
**Reliable pallet position fixing directly below the pushoff carriage. Reliable and gentle handling of new containers. No danger of collapse during the entire depalletizing process.**
- Grippers hold the inserted liners in place during pushoff. **The result: Reliable container pushoff. The inserted liners remain in place.**
- Each layer to be depalletized is centered by a four-sided pushoff carriage.  
**Safe depalletizing down to the last layer even at high speeds.**

Depalletizer with height control





Innopal ASN with handling robot for pallet manipulation

- Servo technology and toothed belts used to drive the pushoff carriage.  
**Less noise, less wear, less servicing effort.**
- All product-contacting surfaces are covered with plastic; the distance plate is made of plastic (PTFE) or stainless steel.  
**Gentle treatment of new containers even at high output speeds.**

- Simple adaptation to various pallet formats.  
**This saves time and increases the versatility of your line.**
- You can process containers of various heights and diameters.  
**This saves you the cost of investment in expensive extra equipment.**
- Wood and steel frames are grasped separately and stacked in different magazines.  
**Perfect packing aid disposal coupled with a continuous time-saving depalletizing process. No operator intervention.**
- Product range for depalletizing:  
**New glass containers up to 400 mm in height.**

#### Technical Specifications

Handling robot in the machine	200 layers per hour
Handling robot in the bottle table area	240 layers per hour
Handling robot in the machine with pallet removal	200 layers per hour
Maximum pallet height	2,400 mm
Pallet dimensions	750 to 1,300 mm in direction of discharge 750 to 1,250 mm across direction of discharge



**KHS Maschinen- und  
Anlagenbau Aktiengesellschaft**

Juchostrasse 20  
44143 Dortmund  
Germany  
Phone +49 (231) 569-0  
Fax +49 (231) 569-1541

Planiger Strasse 139-147  
55543 Bad Kreuznach  
Germany  
Phone +49 (671) 852-0  
Fax +49 (671) 852-2411

Enzingerstrasse 139  
67551 Worms  
Germany  
Phone +49 (6247) 97-0  
Fax +49 (6247) 97-3300

[www.khs-ag.com](http://www.khs-ag.com)  
Email: [info@khs-ag.com](mailto:info@khs-ag.com)