



PadShrinkPacker

The importance of shrinkfilm and cardboard pads as shipping and sales packagings continues to increase. Thanks to the cardboard pad, this type of packaging is also suitable for bigger and heavier products.



Prepacked product groups, loose products, different product diameters and heights, and/or changing pack formations - nearly everything is possible.

The fully automatic KHS Kisters PadShrinkPackers are user-friendly, reliable and flexible in use. Top speeds of up to 120 cycles per minute offer efficient possibilities in the beverage industry as well as in the food and non-food-sectors.



The precise shrinkage of the film around products and additional cardboard pads guarantees a maximum pack stability and highest possible savings in packaging materials.

Your advantages:

- Possibility of equipping the machine with an electronic print positioning system to allow the use of register printed film. This is an important marketing advantage in comparison to unprinted, transparent film
- Automatic speed adaptation to the quantity of products fed in
- Control by short-circuit and pole-reversal proof microprocessors
- An error and diagnosis display integrated in the operator control panel reduces downtime to a minimum
- Automatic centralized lubrication system
- Very high production efficiency
- Short format changeover times
- Either Siemens S7/400 or AB Control Logix controls



Option:

- Dual-lane Version

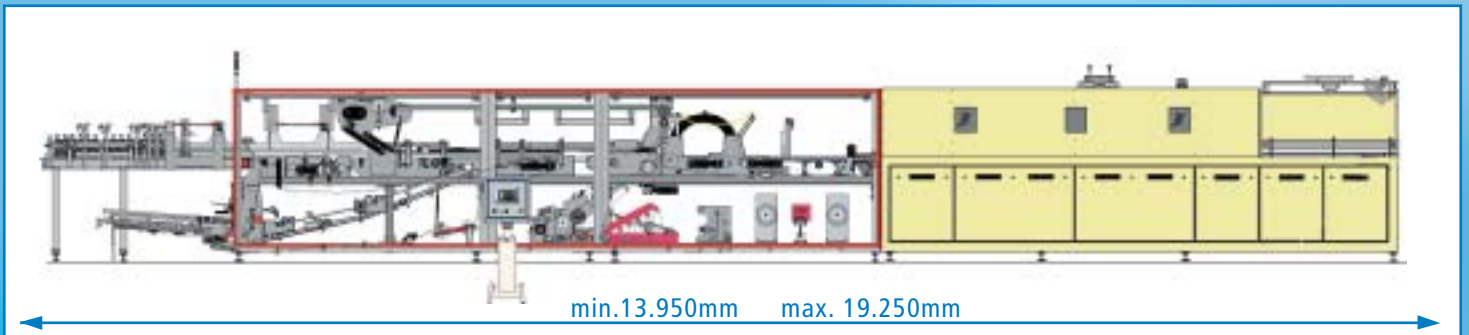

Standard Technical Data Modular PadShrinkPacker

Innopack PSP PadShrink Packer *	
Speed	From 60 up to 120 cycles/minute
Product dimensions	diameter: 48 - 120 mm height: 58 - 360 mm
Film sheets	length: 350 - 1300 mm width: 180 - 880 mm or dust-lane 2 x 180 up to 2 x 400 mm
Film thickness	40 - 90 μ
Pack dimensions (in mm)	
* All maximum values may not apply together	

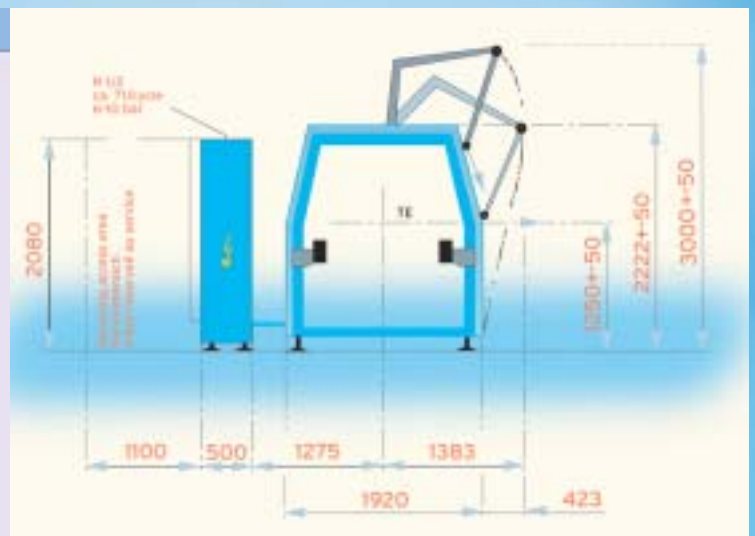

KHS Kisters Maschinenbau GmbH
 Boschstrasse 1-3
 D-47533 Kleve, Germany
 Phone: +49 (2821) 503-0
 Fax: +49 (2821) 26110
 Email: info@kisters.com
 www.kisters.com

KHS Kisters Maschinenbau GmbH
 Werk Bad Arolsen
 Im Kirchfeld 3
 D-34454 Bad Arolsen, Germany
 Phone: +49 (5691) 8909-0
 Fax: +49 (5691) 8909-15
 Email: info-zvt@kisters.com

KHS Kisters, Inc.
 4100 U.S. Highway #1 South
 Edgewater, FL 32141
 U.S.A.
 Phone: +1 (386) 424-0101
 Fax: +1 (386) 424-0266
 Email: sales@kkiusa.com

